

# **WINGET**

Hand Fed Tilting Drum  
Site Mixers



*100T, 150T 175T, 200T  
100TFT, 150TFT, 175TFT*

# WINGET

Hand Fed Tilting Drum  
Site Mixers



**100T (5 / 3.5)** - 100 litres wet batch output  
150 litres dry unmixed capacity.up to 1.2m<sup>3</sup>/hr  
Yanmar electric start diesel engine  
**Standard 4 wheel chassis** - site mobile



**150T (7 / 5)** - 150 litres wet batch output  
200 litres dry unmixed capacity.up to 1.8m<sup>3</sup>/hr  
Yanmar electric start diesel engine  
**Standard 4 wheel chassis** - site mobile



**175T (8.5 / 6.5)** - 175 litres wet batch output  
240 litres dry unmixed capacity.up to 2.1m<sup>3</sup>/hr  
Yanmar electric start diesel engine  
**Standard 4 wheel chassis** - site mobile



**200T (10 / 7)** - 200 litres wet batch output  
285 litres dry unmixed capacity.up to 2.4m<sup>3</sup>/hr  
Yanmar electric start diesel engine  
**Standard 4 wheel chassis** - site mobile



**100TFT (5 / 3.5)** - 100 litres wet batch output  
150 litres dry unmixed capacity.up to 1.2m<sup>3</sup>/hr  
Yanmar electric start diesel engine  
**Fast Tow chassis**



**150TFT (7 / 5)** - 150 litres wet batch output  
200 litres dry unmixed capacity.up to 1.8m<sup>3</sup>/hr  
Yanmar electric start diesel engine  
**Fast Tow chassis**



**175TFT (8.5 / 6.5)** - 175 litres wet batch output  
240 litres dry unmixed capacity.up to 2.1m<sup>3</sup>/hr  
Yanmar electric start diesel engine  
**Fast Tow chassis**

# MIX WITH THE BEST

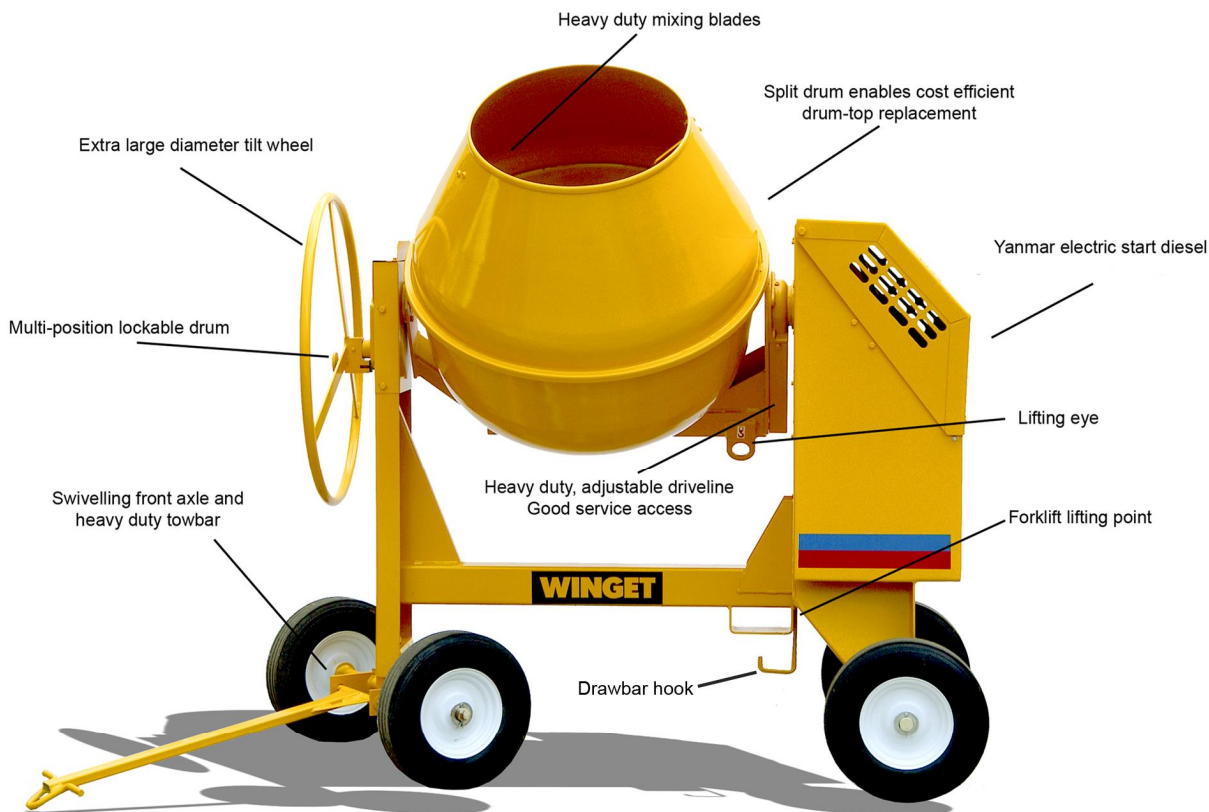

*Models available with mixed batch outputs from 100 to 200 litres*

*Capable of mixing 12 batches per hour giving output rates of 1.2 to 2.4 m<sup>3</sup>/hr*

*Robustly engineered throughout to provide a safe, reliable and long service life*

*Heavy duty, fully enclosed driveline*

*Highly efficient, two piece, heavy gauge spun steel drum*

*WINGET mixers for sale in the EC are CE marked*

*WINGET is an ISO9001 accredited company*

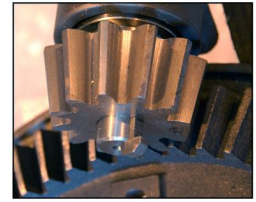

**Chassis:** Heavy duty, box section chassis gives clean lines and less material traps. Fitted with lifting points.

**Drum:** Two piece, spun steel drum assures long life and easy replacement. Highly efficient drum design and twin fast acting blades ensure thorough mixing and eliminate clogging and wasteful 'build-up'.

**Driveline:** Totally enclosed, heavy duty driveline through roller chain or drive belt, bevel wheel and cast steel pinion.

**Access:** Good all round access to daily check points, service items and all replaceable components.

**Operation:** Careful design ensures maximum working space around the machine for charging, mixing and discharging.

**Axles / Wheels:** Fixed rear axle and swivelling front axle fitted with four rubber cushion tyres and towbar on standard 4 wheel model or 2 pneumatic tyres (with mudguards) and towbar on fast tow model.



Yanmar L48 electric start diesel

**Noise Levels:** 100T, 150T, 175T - 80LPA / 101LWA.  
200T - 80 LPA / 101LWA

CAPACITIES	100T / 100TFT	150T / 150TFT	175T / 175TFT	200T
Mixed batch output	100 litres	150 litres	175 litres	200 litres
Unmixed capacity	150 litres	200 litres	240 litres	285 litres
Gross drum volume	263 litres	362 litres	377 litres	485 litres
Drum speed	22 rev/min	22 rev/min	22 rev/min	22 rev/min
Production rate (max)	1.2 m <sup>3</sup> /hr	1.8 m <sup>3</sup> /hr	2.1 m <sup>3</sup> /hr	2.4 m <sup>3</sup> /hr

STANDARD MODELS	100T	150T	175T	200T
<b>A</b> Overall Length	1.55m	1.65m	1.70m	2.17M
<b>B</b> Overall Width	0.82m	0.93m	0.93m	1.11m
<b>C</b> Overall Height	1.57m	1.71m	1.77m	1.82m
<b>D</b> Loading Height	1.00m	1.10m	1.11m	1.13m
<b>E</b> Discharge Height	0.54m	0.57m	0.52m	0.66m
Machine weight	370kg	410kg	460kg	600kg

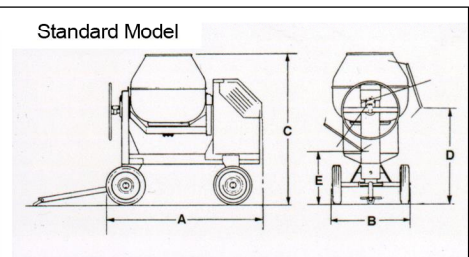

FAST TOW MODELS	100TFT	150TFT	175TFT
<b>A1</b> Overall Length (operational)	1.72m	1.91m	2.06m
<b>A2</b> Overall Length (for transportation)	2.37m	2.48m	2.64m
<b>B</b> Overall Width	1.24m	1.32m	1.35m
<b>C</b> Overall Height	1.63m	1.77m	1.34m
<b>D</b> Loading Height	1.06m	1.14m	1.18m
<b>E</b> Discharge Height	0.60m	0.61m	0.59m
<b>F</b> Height to Towbar	0.43m	0.48m	0.45m
Machine weight	395kg	482kg	500kg

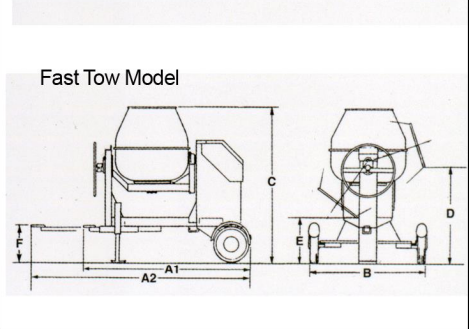

**Winget Limited**

PO Box 41, Edgefold Industrial Estate  
Bolton, BL4 0LS, England.

Tel: +44 (0)1204 854650, Fax: +44 (0)1204 854664  
email: sales@winget.co.uk, www.winget.co.uk

Dealer Stamp

